

# Chevrolet/GMC T-SERIES PICKUP 4WD . GMC SONOMA PICKUP 4WD

## Front

REFER TO TRANSFER CASE INFORMATION ON THE FACING PAGE.

Refer to Notices on pages 28-29.

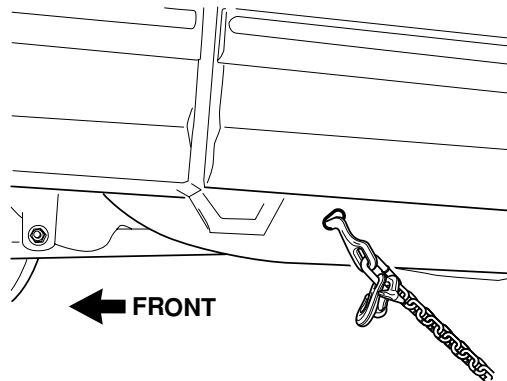

IF MODE POSITION CAN BE VERIFIED



IF MODE POSITION CANNOT BE VERIFIED



## Rear

REFER TO TRANSFER CASE INFORMATION ON THE FACING PAGE.

Refer to Notices on pages 28-29.

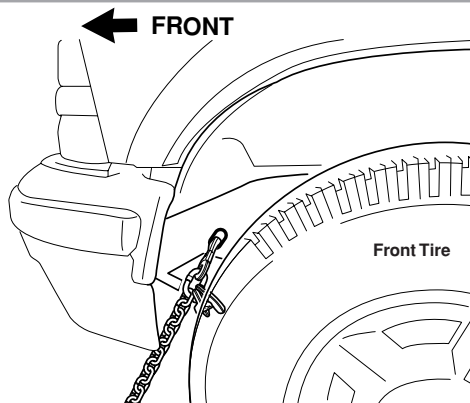

IF MODE POSITION CAN BE VERIFIED



IF MODE POSITION CANNOT BE VERIFIED



**IF THE TRANSFER CASE MODE POSITION CAN BE VERIFIED, USE ONE OF THE FOLLOWING PROCEDURES (A OR B) FOR WHEEL LIFT FRONT TOWING:**

**— A —**

- Place the transfer case in NEUTRAL (N)
- Place the automatic transmission in PARK (P)
- Adhere to the speed limit as posted. Speed is any legal speed, unlimited distance

**— B —**

- Place the transfer case in 2HI
- Place the automatic transmission in NEUTRAL (N)
- Adhere to a maximum speed of 35 MPH (55 km/H) and maximum distance of 50 miles (80 km)

**IF THE TRANSFER CASE MODE POSITION CANNOT BE VERIFIED, USE THE FOLLOWING PROCEDURE FOR WHEEL LIFT FRONT TOWING:**

1. Use a dolly under the rear wheels — OR —
2. Remove the rear propshaft

**— FAILURE TO FOLLOW THESE PROCEDURES CAN RESULT IN VEHICLE/POWERTRAIN DAMAGE —**

**IF THE TRANSFER CASE MODE POSITION CAN BE VERIFIED, USE THE FOLLOWING PROCEDURE FOR WHEEL LIFT REAR TOWING:**

- Place the transfer case in 2HI or NEUTRAL (front axle disengaged)
- Place the automatic transmission in PARK (P)
- Adhere to the speed limit as posted. Speed is limited to any legal speed for unlimited distance

**IF THE TRANSFER CASE MODE POSITION CANNOT BE VERIFIED, THE FOLLOWING PROCEDURE MUST BE FOLLOWED FOR WHEEL LIFT REAR TOWING:**

1. Use a dolly under the rear wheels — OR —
2. Remove the front propshaft

**— FAILURE TO FOLLOW THESE PROCEDURES CAN RESULT IN VEHICLE/POWERTRAIN DAMAGE —**

**Front**

Refer to Notices on pages 28-29.

**NOTICE:** It is highly recommended that you use carrier equipment when towing 4WD vehicles. The following instructions apply to the towing of 4WD vehicles when using wheel-lift equipment.

**NOTICE:** These 4WD procedures apply to manual and automatic transmissions.

**Rear**

Refer to Notices on pages 28-29.

**NOTICE:** It is highly recommended that you use carrier equipment when towing 4WD vehicles. The following instructions apply to the towing of 4WD vehicles when using wheel-lift equipment.

**NOTICE:** These 4WD procedures apply to manual and automatic transmissions.

# Towing Recommendations and Guidelines

The following notices describe precautions necessary to prevent damage to towed vehicles. Refer and adhere to these notices whenever towing a GM vehicle. In addition to the general notices below, individual vehicles may require additional precautions due to the vehicle's design, equipment, or other unique features. These vehicle-specific notices are included on the appropriate vehicle page. They should be adhered to in addition to the notices below. The following pages also contain guidelines for vehicle content features that affect towing. These should also be adhered to, as applicable, in addition to all applicable notices. **Failure to follow these notices and guidelines may result in damage to the customer's vehicle.**

These instructions apply to vehicles with standard equipment only. Any optional equipment such as campers, special bodies, front mounted spare tires, trailer hitches, etc. must be given due consideration.

## Front Tow Notices

**NOTICE:** Towing on a vehicle's drive wheels should be avoided, if possible. When towing on the drive wheels, maximum speed and distance limitations must be adhered to and/or a towing dolly may need to be used.

**NOTICE:** When towing most AWD vehicles, a towing dolly must be used on the ground wheels or vehicle damage will occur.

**NOTICE:** Do not tow with sling-type equipment or fascia/fog lamp damage will occur. Use wheel-lift or carrier equipment. Additional ramping may be required for car-carrier equipment. Use safety chains and wheel straps.

**NOTICE:** Towing a vehicle over rough surfaces could damage the vehicle. Damage can occur from vehicle-to-ground or vehicle-to-wheel-lift equipment contact. To help avoid damage, install a towing dolly and raise vehicle until adequate clearance is obtained between the ground and/or wheel-lift equipment.

**NOTICE:** Do not attach winch cables or J-hooks to suspension components when using carrier equipment. Always use T-hooks inserted in the shipping slots.

**NOTICE:** Towing on a vehicle's drive wheels should be avoided, if possible. When towing on the drive wheels, maximum speed and distance limitations must be adhered to and/or a towing dolly may need to be used.

**NOTICE:** When towing most AWD vehicles, a towing dolly must be used on the ground wheels or vehicle damage will occur.

**NOTICE:** Do not tow with sling-type equipment or the rear bumper valance will be damaged. Use wheel-lift or carrier equipment. Additional ramping may be required for carrier equipment. Use safety chains and wheel straps.

**NOTICE:** Towing a vehicle over rough surfaces could damage the vehicle. Damage can occur from vehicle-to-ground or vehicle-to-wheel-lift equipment contact. Install the towing dolly and raise the vehicle until adequate clearance is obtained between the ground and/or wheel-lift equipment contact.

**NOTICE:** Do not attach winch cables or J-hooks to suspension components when using carrier equipment. Always use T-hooks inserted in the shipping slots.

**NOTICE:** Wheel-lift towing pickup trucks models from the rear while loaded with heavy cargo may cause the frame side rails to flex sufficiently, allowing the pickup box to contact the cab and possibly causing damage to the cab and/or box.