

- Wheel lift towing, using axle lift forks, is recommended over spring adaptors or sling type equipment.
- Tow vehicle from the front, as picking it up from the rear may overload the front axle.
- Secure the steering wheel to maintain a straight-ahead position.
- Do not exceed towing manufacturers equipment ratings.
- Verify towed vehicle's wheels are free to roll. Make sure they are not locked by the transmission or parking brakes.
- Always use safety chains.

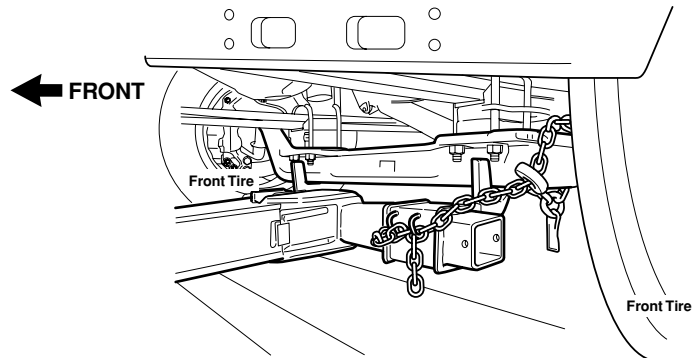
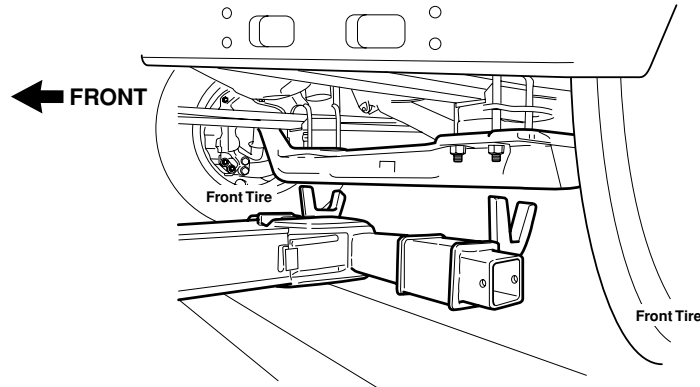

### Front

Refer to Notices on pages 28-29.

**NOTICE:** The propshaft must be disconnected prior to towing this vehicle. Failure to do so can cause serious transmission damage.

## MEDIUM DUTY TRUCKS (GMC Topkick/Chevy Kodiak)

SERIES	PLATFORM	BODY STYLE	GVWR (lb.)
C4500	C4C	Conventional Cab	16,000
	C4E	Crew Cab	16,000
	C4U	Motor Home Chassis	16,000
	C4V	Commercial Cutaway Chassis	16,000
C5500	C5C	Conventional Cab	19,500
	C5E	Crew Cab	19,500
	C5U	Motor Home Chassis	19,500
	C5V	Commercial Cutaway Chassis	19,500
C5500	C5V	Schoolbus Chassis	26,000

Payload capacities cannot be determined due to the large number of build combinations, such as frame lengths, engine, transmission, optional equipment, etc.

# Towing Recommendations and Guidelines

The following notices describe precautions necessary to prevent damage to towed vehicles. Refer and adhere to these notices whenever towing a GM vehicle. In addition to the general notices below, individual vehicles may require additional precautions due to the vehicle's design, equipment, or other unique features. These vehicle-specific notices are included on the appropriate vehicle page. They should be adhered to in addition to the notices below. The following pages also contain guidelines for vehicle content features that affect towing. These should also be adhered to, as applicable, in addition to all applicable notices. **Failure to follow these notices and guidelines may result in damage to the customer's vehicle.**

These instructions apply to vehicles with standard equipment only. Any optional equipment such as campers, special bodies, front mounted spare tires, trailer hitches, etc. must be given due consideration.

## Front Tow Notices

**NOTICE:** Towing on a vehicle's drive wheels should be avoided, if possible. When towing on the drive wheels, maximum speed and distance limitations must be adhered to and/or a towing dolly may need to be used.

**NOTICE:** When towing most AWD vehicles, a towing dolly must be used on the ground wheels or vehicle damage will occur.

**NOTICE:** Do not tow with sling-type equipment or fascia/fog lamp damage will occur. Use wheel-lift or carrier equipment. Additional ramping may be required for car-carrier equipment. Use safety chains and wheel straps.

**NOTICE:** Towing a vehicle over rough surfaces could damage the vehicle. Damage can occur from vehicle-to-ground or vehicle-to-wheel-lift equipment contact. To help avoid damage, install a towing dolly and raise vehicle until adequate clearance is obtained between the ground and/or wheel-lift equipment.

**NOTICE:** Do not attach winch cables or J-hooks to suspension components when using carrier equipment. Always use T-hooks inserted in the shipping slots.

**NOTICE:** Towing on a vehicle's drive wheels should be avoided, if possible. When towing on the drive wheels, maximum speed and distance limitations must be adhered to and/or a towing dolly may need to be used.

**NOTICE:** When towing most AWD vehicles, a towing dolly must be used on the ground wheels or vehicle damage will occur.

**NOTICE:** Do not tow with sling-type equipment or the rear bumper valance will be damaged. Use wheel-lift or carrier equipment. Additional ramping may be required for carrier equipment. Use safety chains and wheel straps.

**NOTICE:** Towing a vehicle over rough surfaces could damage the vehicle. Damage can occur from vehicle-to-ground or vehicle-to-wheel-lift equipment contact. Install the towing dolly and raise the vehicle until adequate clearance is obtained between the ground and/or wheel-lift equipment contact.

**NOTICE:** Do not attach winch cables or J-hooks to suspension components when using carrier equipment. Always use T-hooks inserted in the shipping slots.

**NOTICE:** Wheel-lift towing pickup trucks models from the rear while loaded with heavy cargo may cause the frame side rails to flex sufficiently, allowing the pickup box to contact the cab and possibly causing damage to the cab and/or box.