

# Chevrolet SILVERADO 4WD · GMC SIERRA 4WD – 1500 & 2500 series

## Front

REFER TO TRANSFER CASE INFORMATION ON THE FACING PAGE.

Refer to Notices on pages 28-29.

Refer to Four Wheel Steering (QUADRASTEER) information on page 31.

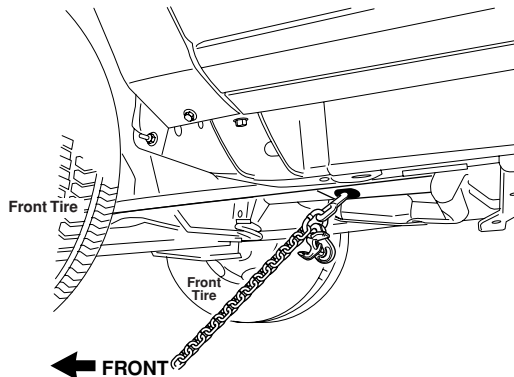

IF TRANSFER CASE HAS SELECTABLE NEUTRAL



IF TRANSFER CASE CANNOT BE VERIFIED



## Rear

REFER TO TRANSFER CASE INFORMATION ON THE FACING PAGE.

Refer to Notices on pages 28-29.

Refer to Four Wheel Steering (QUADRASTEER) information on page 31.

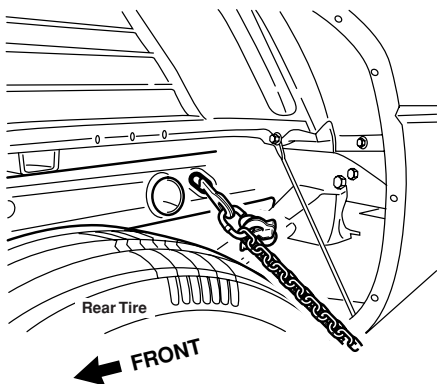

IF TRANSFER CASE HAS SELECTABLE NEUTRAL



IF TRANSFER CASE CANNOT BE VERIFIED



**IF THE TRANSFER CASE HAS A SELECTABLE NEUTRAL POSITION:**

- Place the transfer case in Neutral (N)
- Place automatic transmission in Park/place manual transmission in highest gear range
- Follow legal speed limit
- The vehicle may be towed for an unlimited distance

**IF THE TRANSFER CASE MODE POSITION CANNOT BE VERIFIED, THE FOLLOWING MUST BE ADHERED TO:**

- Use a dolly under the wheels  
— OR —
- Remove the propshaft

**Front & Rear**

Refer to Notices on pages 28-29.

# Towing Recommendations and Guidelines

The following notices describe precautions necessary to prevent damage to towed vehicles. Refer and adhere to these notices whenever towing a GM vehicle. In addition to the general notices below, individual vehicles may require additional precautions due to the vehicle's design, equipment, or other unique features. These vehicle-specific notices are included on the appropriate vehicle page. They should be adhered to in addition to the notices below. The following pages also contain guidelines for vehicle content features that affect towing. These should also be adhered to, as applicable, in addition to all applicable notices. **Failure to follow these notices and guidelines may result in damage to the customer's vehicle.**

These instructions apply to vehicles with standard equipment only. Any optional equipment such as campers, special bodies, front mounted spare tires, trailer hitches, etc. must be given due consideration.

## Front Tow Notices

**NOTICE:** Towing on a vehicle's drive wheels should be avoided, if possible. When towing on the drive wheels, maximum speed and distance limitations must be adhered to and/or a towing dolly may need to be used.

**NOTICE:** When towing most AWD vehicles, a towing dolly must be used on the ground wheels or vehicle damage will occur.

**NOTICE:** Do not tow with sling-type equipment or fascia/fog lamp damage will occur. Use wheel-lift or carrier equipment. Additional ramping may be required for car-carrier equipment. Use safety chains and wheel straps.

**NOTICE:** Towing a vehicle over rough surfaces could damage the vehicle. Damage can occur from vehicle-to-ground or vehicle-to-wheel-lift equipment contact. To help avoid damage, install a towing dolly and raise vehicle until adequate clearance is obtained between the ground and/or wheel-lift equipment.

**NOTICE:** Do not attach winch cables or J-hooks to suspension components when using carrier equipment. Always use T-hooks inserted in the shipping slots.

**NOTICE:** Towing on a vehicle's drive wheels should be avoided, if possible. When towing on the drive wheels, maximum speed and distance limitations must be adhered to and/or a towing dolly may need to be used.

**NOTICE:** When towing most AWD vehicles, a towing dolly must be used on the ground wheels or vehicle damage will occur.

**NOTICE:** Do not tow with sling-type equipment or the rear bumper valance will be damaged. Use wheel-lift or carrier equipment. Additional ramping may be required for carrier equipment. Use safety chains and wheel straps.

**NOTICE:** Towing a vehicle over rough surfaces could damage the vehicle. Damage can occur from vehicle-to-ground or vehicle-to-wheel-lift equipment contact. Install the towing dolly and raise the vehicle until adequate clearance is obtained between the ground and/or wheel-lift equipment contact.

**NOTICE:** Do not attach winch cables or J-hooks to suspension components when using carrier equipment. Always use T-hooks inserted in the shipping slots.

**NOTICE:** Wheel-lift towing pickup trucks models from the rear while loaded with heavy cargo may cause the frame side rails to flex sufficiently, allowing the pickup box to contact the cab and possibly causing damage to the cab and/or box.

## Remote Keyless Entry

If the vehicle has Remote Keyless Entry, it also has the Content Theft Deterrent feature. If the vehicle is towed as recommended (with the ignition in the OFF/UNLOCK position or, if necessary, with the ignition OFF and the key removed), it may be necessary to do one of the following:

1. Prior to towing, do not lock the car doors with the remote keyless entry fob. Do not enable content theft deterrence.
2. Remove the BCM/CLU fuse in the instrument panel fuse block. This is located under the driver's side instrument panel cover. After towing, remember to replace the fuse to restore normal vehicle operation.

QUADRASTEER (also known as a Steerable Rear Axle or Four Wheel Steering) is an option on select 1500 Series (1/2 ton) vehicles. These can be identified by the QUADRASTEER emblem on the cab.

**CAUTION:** Use care in tight parking situations when the rear wheels are turned and no power is available. These vehicles are equipped with a “return to center” spring which will straighten the rear wheels as the vehicle rolls.

## Four-Wheel Steering (“QUADRASTEER”)

When towing a Compressed Natural Gas vehicle, install a towing dolly and raise the vehicle until adequate clearance is obtained between the ground and/or wheel lift equipment. A CNG vehicle can be identified by the CNG label on the right rear door.

## Compressed Natural Gas (CNG) Vehicles