

## Inertia switch

In the event of an accident, an inertia switch will trip, isolating fuel pump operation. Once the switch has tripped it must be reset before attempting to restart the engine.

The inertia switch is located behind the trim on the left-hand side of the vehicle, forward of the front door post, below the fascia. A finger access hole in the trim allows the driver to reset the switch.

## Resetting the switch



### **WARNING:**

**To avoid the possibility of fire or personal injury, do not reset the inertia switch if you see or smell fuel.**

If no fuel leak is apparent, reset the inertia switch as follows:

1. Turn the ignition switch to position '0'.
2. Press down the rubber reset button on the top of the inertia switch.
3. Turn the ignition switch to position 'II', pause for a few seconds, then return the key to position '0'.
4. Make a further check for fuel leaks.

## 6-2 Roadside emergency

---

### Emergency starting

#### Rolling start

If the vehicle battery is discharged, inserting the ignition key may not release the electronically controlled steering lock. Also, if the electric parkbrake was applied before the battery was discharged (e.g. vehicle unused for a long period), it will not be possible to release the parkbrake.

In this situation, a manual transmission vehicle cannot be pushed or tow started. If the parkbrake has not been applied, it could be dangerous to attempt to move the vehicle with the steering locked.

Do not push or tow start a vehicle with automatic transmission even with the steering lock and parkbrake released. With a discharged battery it will also not be possible to move the drive selector from the 'P' position.



#### **WARNING:**

**A vehicle start by pushing or towing must not be attempted because it is possible that the steering lock may not be disengaged. Only jump lead starting or the fitting of a fully charged battery is recommended.**

#### Emergency starting using jump leads

Both the booster and discharged battery should be treated with great care when using jump leads. Always use high quality leads capable of carrying the starter current of the vehicle to be started.

Before commencing, the following precautions must be taken:

- When the battery of another vehicle is being used, ensure that the vehicles do not touch. Alternatively, remove the charged battery and place near to, not on, the vehicle with the discharged battery.
- Ensure that both vehicles have all electrical services OFF, the parkbrakes applied and neutral (manual transmission) or 'P' (automatic transmission) selected.
- Where the jump leads are of a different colour, e.g. red and black, use red for positive (+). This aids identification and helps to avoid crossing positive (+) to negative (-). Take extra care to avoid crossing the polarity when using cables of the same colour.

#### **Caution:**

1. **If using a jump start vehicle, under no circumstances should the vehicles come into contact with each other. This could establish an earth connection, which may cause sparks and damage.**
2. **Do not run the jump start vehicle's engine when boost starting a Jaguar Vehicle. If the jump start vehicle's engine is running and the jump leads are disconnected, damage to the Jaguar vehicle's electrical system will result.**
3. **The booster battery voltage must not exceed 12 volts.**

To gain access to the battery, fold the luggage compartment floor panel forward. If a space saver spare wheel is fitted it will be necessary to remove the under floor stowage tray.

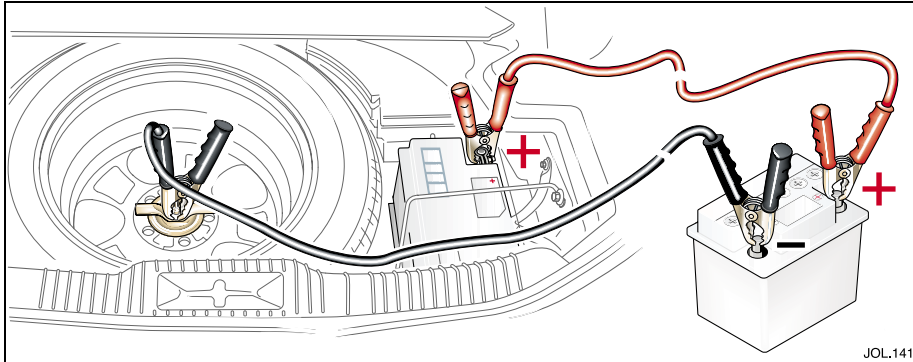

### Emergency starting using jump leads (continued)

The following procedure must be followed exactly, being careful not to cause sparks:

1. Unclip the battery positive (+) terminal cover.
2. Attach one end of the red jump lead to the positive (+) terminal of the booster battery and the other end to the positive (+) terminal of the discharged battery. Make sure that a good connection is made.

**Caution:** Do not connect the negative jump lead directly to the negative (-) terminal of the discharged vehicle.

3. Attach one end of the black jump lead to the negative (-) terminal of the booster battery and the other end to an earth point on the vehicle being started. (If your Jaguar has the discharged battery use only the spare wheel locking stud, as shown.) The earth point must be at least 12 inches (305 mm) from the discharged battery. Make sure that a good connection is made.

4. When started, allow the engine to idle for five minutes before disconnecting the cables.
5. Disconnect the black jump lead from the earth point and the booster battery negative (-) terminal.
6. Disconnect the red jump lead from the positive (+) terminals of both batteries.
7. Refit the positive (+) terminal cover.
8. Refit the luggage compartment floor panels.

After starting the engine, it may be necessary to reset the electric parkbrake as described in Section 4. See also **After battery reconnection**, Section 7.

## 6-4 Roadside emergency

### Wheel changing and jacking

Be prepared for a flat tyre. Know where equipment is stowed and read the wheel changing and jacking instructions carefully.

Pull off the road completely, clear of all traffic and park on as level, solid ground as possible. Switch on hazard warning lights and, where legally required, display the warning triangle.



#### **WARNING:**

**It can be dangerous to change a wheel when the vehicle is on a slope or soft, uneven ground.**

The spare wheel and jacking equipment are stored under the luggage compartment floor panel.

To remove the spare wheel, fold the luggage compartment floor panel towards the rear seats. Remove the tray containing the jacking equipment to gain access to the wheel. Unscrew the retaining nut and remove the spare wheel. Remove the jack and wheel nut wrench.

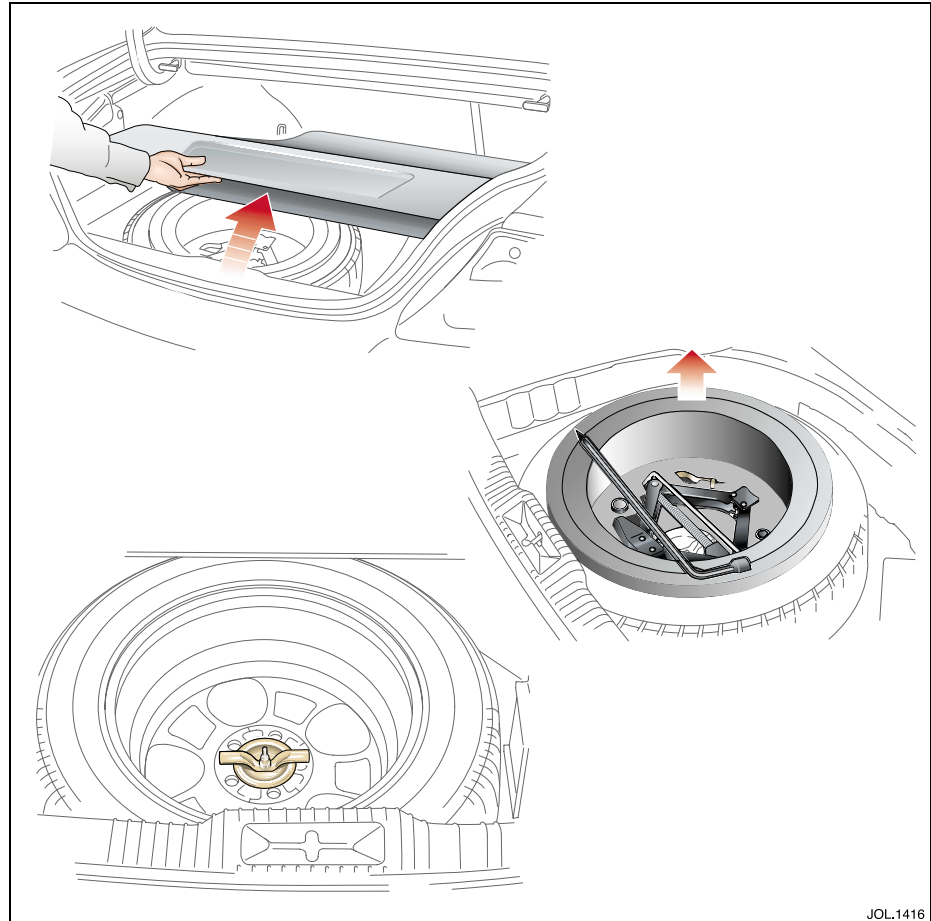

## Temporary-use spare wheel

Observe the following warnings before using the wheel:



### WARNING:

1. Please note temporary-use spare wheel warning label. Adhere to instructions on the label. Failure to comply can be dangerous.
2. When a temporary-use spare wheel is fitted, drive with caution and replace with the specified wheel and tyre as soon as possible.
3. Do not fit more than one temporary-use spare wheel and tyre assembly at one time.
4. The temporary-use spare wheel must be inflated to the correct pressure.
5. Temporary-use spare wheel, maximum speed is 50 mph (80 km/h).

**Note:** Maintenance information for the temporary-use spare wheel is the same as given for normal tyres.

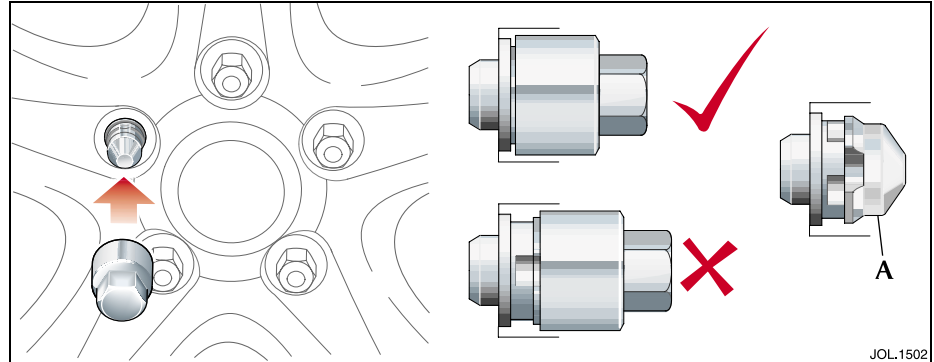

## Locking wheel nuts

Where Jaguar locking wheel nuts are fitted (one on each wheel), they can only be removed using the correct key socket.

The locking wheel nut comprises two grooved parts, front and rear, which must be turned together to allow the nut to be fitted or removed.

To remove the nut, the front and rear grooves must be aligned. Locate the key socket in the grooves and push it fully over both parts of the nut. Fit the wheel nut wrench over the key socket and loosen the locking wheel nut.

Attempting to remove the nut without the correct key socket (such as attempted theft) or with the socket not located over the rear part of the nut, will cause the front part only (A) to turn.

If this has happened, rotate the front part with the key socket until the grooves are re-aligned and then push the socket fully over the nut.

Should a new key socket be required, contact your Jaguar Dealer. Proof of vehicle ownership will be required.

## 6-6 Roadside emergency

### Wheel changing

1. Ensure that all passengers are in a safe place, clear of the vehicle.
2. Apply the parkbrake and select gear position 'P' (Park) or select a low gear on a manual transmission vehicle.
3. Ensure that the jack is placed on firm and level ground.

**Note:** When one rear wheel is lifted off the ground the selection of a low gear on manual vehicles or automatic transmission 'P' (Park) position will not prevent the vehicle from moving and possibly slipping off the jack.



#### **WARNING:**

1. **Before attempting to lift the vehicle with the jack, chock the wheel diagonally opposite to the wheel being replaced to prevent the vehicle from rolling when jacked up. A wheel chock is supplied with the jacking equipment for this purpose.**
2. **Never work under the vehicle using only the jack as a support, always use axle stands or suitable supports under the jacking points.**

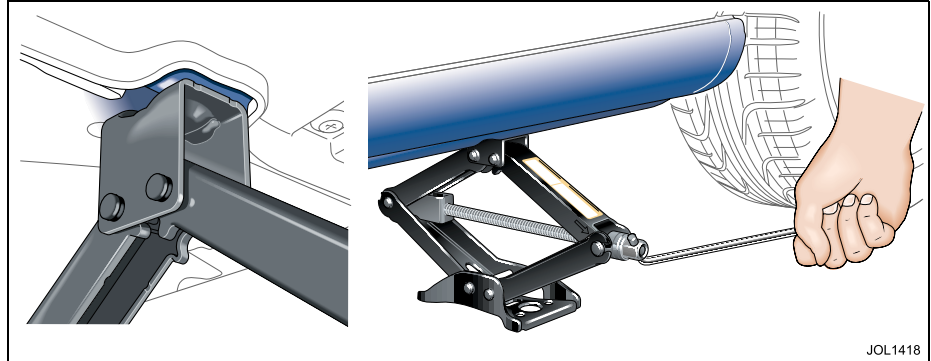

Before raising the vehicle slacken but do not remove the wheel nuts.

Observe the instructions printed on the jack.

Use the jack only for lifting the vehicle during wheel changing, and only use the jack which is stored in the vehicle.

Do not start or run the engine while the vehicle is only supported by a jack.

There are four jacking points, two each side of the vehicle on the underside of the floor. These provide positive location for the jack. The front jacking point is approximately 7 inches (180 mm) from the front wheel and the rear is approximately 11 inches (280 mm) forward of the rear wheel.

The simplest way to correctly locate the jacking point is to feel along the sill panel to the cut-away portion and then fit the jack to the body, **not to the sill panel.**

On some models, the jack location points are identified by indented, triangular markers on each sill panel.

**Caution:** Ensure before raising the vehicle that the jack is correctly positioned to avoid any damage to the vehicle sills or sill panels. Use only the correct jacking points, never use bumpers or any other part of the body to lift the vehicle.



## WARNING:

1. Do not attempt to lift the vehicle unless the jack head is fully engaged in the jacking point.
2. Ensure that the parkbrake is applied.

Place the jack squarely beneath the appropriate jacking point. Ensure that the jack head is fully engaged. Carefully raise the vehicle by turning the handle. Stop jacking the vehicle when the tyre just clears the ground. Minimum tyre lift gives maximum vehicle stability.

Remove the wheel nuts and the wheel.

When changing the alloy road wheels, transfer the centre badge to the replacement wheel (when a full size spare wheel is used). Using the plastic tipped end of the wheel nut wrench handle from the inside of the wheel, push the centre badge from its housing. Push the centre badge into the replacement wheel. If the temporary-use spare wheel is to be fitted, keep the centre badge safely and fit it to the repaired full size wheel when it has been refitted.

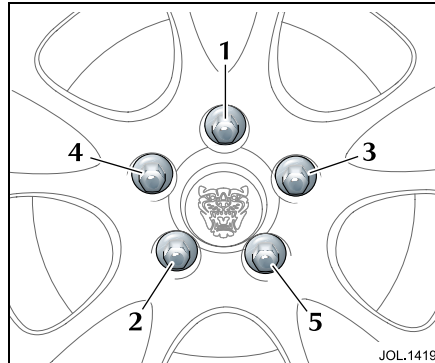

Fit the spare wheel and loosely secure with the wheel nuts.

Using the wheel nut wrench, lightly tighten the wheel nuts alternately using the sequence shown in the illustration.

Lower the jack and tighten the wheel nuts alternately, DO NOT OVERTIGHTEN.

At the earliest opportunity have the wheel nuts tightened with a torque wrench to 92 lb.ft (125 Nm).

This torque must not be exceeded.

## Stowing the equipment

Stow the replaced road wheel in the luggage compartment, position the wheel and secure with the retaining nut.

Place the storage tray with the jack and wrench over the wheel.

Reposition the luggage compartment floor panel.

**Note:** Examine the jack occasionally and clean and grease the threads to ensure it is always ready for an emergency.



## WARNING:

**When the temporary-use spare wheel has been fitted, drive with caution and replace with the specified wheel and tyre as soon as possible.**

## 6-8 Roadside emergency

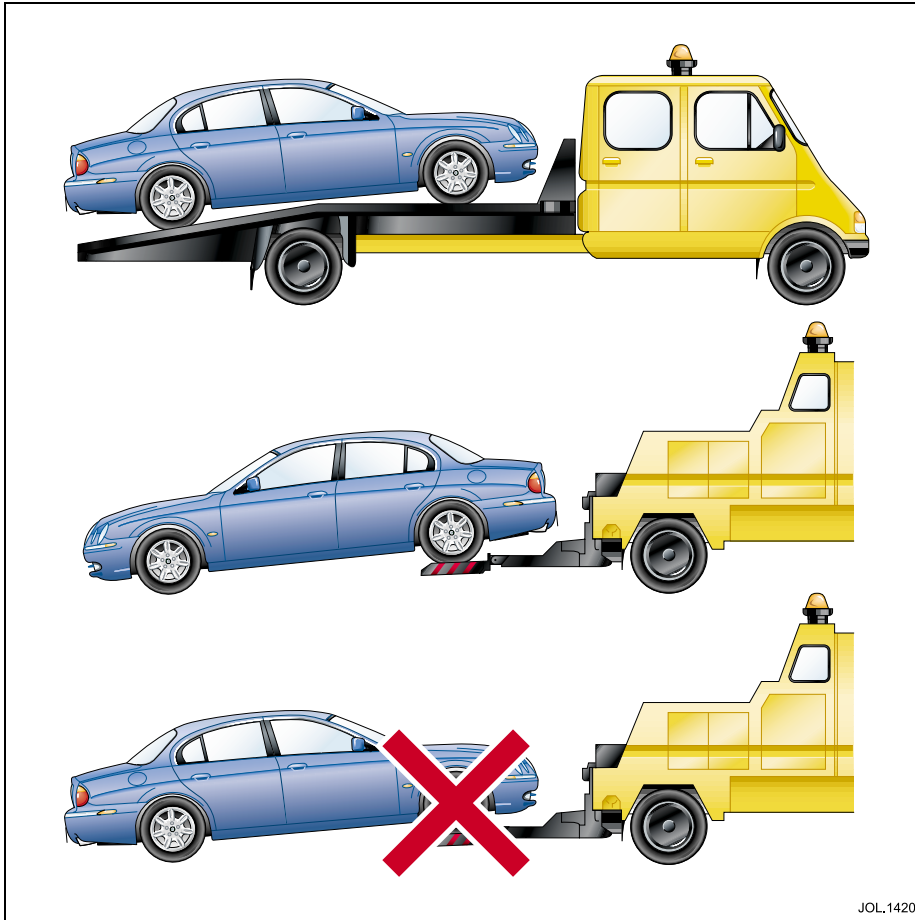

JOL.1420

### Vehicle recovery

The preferred vehicle recovery method is by using a flat bed transporter or rear suspended tow.

#### Caution:

- If the vehicle has defective transmission, to prevent further damage, it must be towed with the rear wheels clear of the ground.
- Ensure that the recovery team do not tow with sling-type equipment since damage to the bodywork may result.
- Do not tow vehicle by suspending the front end.

### Transporting

If the vehicle is being transported on a trailer or vehicle flat bed transporter, the parkbrake must be applied, the wheels chocked and the gear selector lever moved to position 'N' or 'D' but NEVER to 'P'.

The vehicle must be securely tied down to the transporter or trailer.



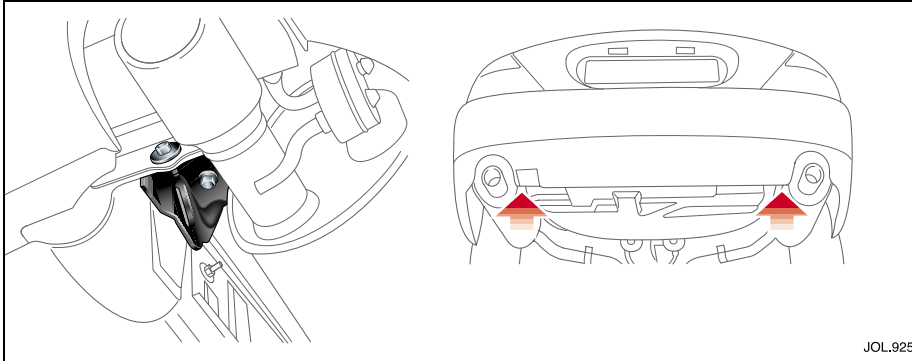

## Transporter tie down brackets



### **WARNING:**

**Avoid body contact with a hot exhaust pipe when using the tie down points.**

There are two transporter tie-down brackets on the vehicle rear underbody. The brackets are inboard of the rear silencer tail pipes.

Use straps on the front wheels/tyres to secure the vehicle for transportation.

The towing eye is not designed for securing the vehicle during transportation.

## Vehicle failure

The removable towing eye is primarily for emergency use when towing for SHORT DISTANCES, e.g. removing the vehicle if it is causing an obstruction or for winching the vehicle onto a recovery transporter. To prevent damage to the automatic transmission whilst the vehicle is being towed with the rear wheels on the ground, towing distance must be restricted to 0.5 miles (0.8 kilometres). Towing speed must not exceed 30 mph (48 km/h).

Always obey towing regulations. In certain countries the registration number of the towing vehicle and an 'ON TOW' sign or warning triangle must be displayed in a prominent position at the rear of the vehicle being towed.

When being towed, the vehicle's gear selector lever must be in neutral (position 'N') with the ignition key turned to position 'II' to release the steering lock and render the indicators, horn and brake lights operational.



### **WARNING:**

**When the engine is not running the steering and brakes will no longer be power-assisted. Therefore, be prepared for relatively heavy steering and the need for greatly increased brake pedal pressure.**

## 6-10 Roadside emergency

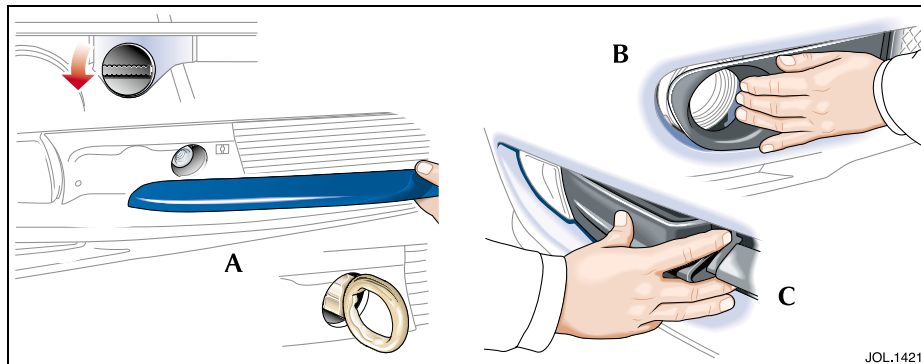

### Towing eye

A screw-in towing eye is provided in the luggage compartment with the jack and can be fitted to the front or rear of the vehicle. The towing eye has a left-hand thread and must be screwed in an anti-clockwise direction when fitting.

#### Caution:

1. The towing eye is not suitable for 'solid bar' towing.
2. Care must be taken to avoid damaging the bumpers and front apron.

### Front tow point

The front towing point is located behind a grille vane or plastic cover on the left-hand side of the vehicle (as viewed from the front).

- A. The grille vane is secured by three fasteners on the underside. Turn the fasteners anti-clockwise to loosen, then remove the grille vane.
- B. On 'R' performance vehicles, press the plastic cover to the right to unclip. Remove the cover.
- C. On vehicles fitted with adaptive cruise control (ACC), unclip the right-hand side of the plastic cover to remove.

Screw the towing eye into the vehicle, right up to the shoulder, turning anti-clockwise.

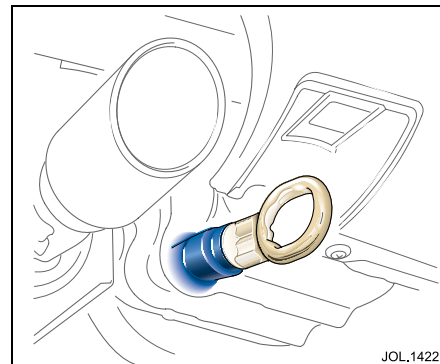

### Rear tow point



**WARNING:**  
Avoid body contact with a hot exhaust pipe when fitting the eye to the rear towing point.

The rear towing point is alongside the left-hand exhaust pipe.

Remove the small cover from the bumper. Remove the bung and screw the towing eye into the vehicle, right up to the shoulder, turning anti-clockwise.

# **New Jaguar S-TYPE 2003MY**

## **Operation of Electric Park Brake –Vehicles in Transit**

### **Operational Key Points**

**This vehicle is fitted with an Automatic Electric Park Brake Mechanism**

**This vehicle is also fitted with a transit device, which disconnects the vehicles electrical system from the vehicle battery when the ignition is switched off**

**As a result the following will occur**

- Electric park brake will automatically be engaged each time the ignition is turned off
- A message will be displayed on the instrument panel message center which reads "**Apply Park Brake**" when the ignition is switched on
- **To move the vehicle**, the brake pedal must be depressed while lifting the Electric Park Brake Switch upwards ( EPB switch is located behind the selector lever see fig. 1) . This will initialise the Electric Park Brake System
- Once Electric Park Brake System has been initialised the park brake will disengage automatically once the vehicle begins to move.

**Failure to adhere to this procedure will result in the rear brake discs overheating which may cause the brake disc bags to catch fire. Additional vehicle components may also be damaged.**

**All expenses required to repair the vehicle will be charged to the appropriate party.**

# New Jaguar S-TYPE 2003MY

Please ensure that all relevant personnel responsible for unloading / loading vehicles are familiar with this procedure. This will need to be reviewed with each team



Figure 1



Figure 2



Figure 3