

Resetting the switch



WARNING:

To avoid the possibility of fire or personal injury, do not reset the inertia switch if you see or smell fuel.

If no fuel leak is apparent, reset the inertia switch as follows:

1. Turn the ignition switch to position '0'.
2. Press down the flexible cover on the top of the inertia switch.
3. Turn the ignition switch to position 'II', pause for a few seconds, then return the key to position '0'.
4. Make a further check for fuel leaks.

Inertia switch

In the event of an accident, an inertia switch will trip, isolating fuel pump operation. Once the switch has tripped it must be reset before attempting to restart the engine.

The inertia switch is located behind the trim on the left-hand side of the vehicle, forward of the front door post, below the fascia. A finger access hole in the trim allows the driver to reset the switch.

5-2 Roadside emergency

Emergency starting

Rolling start



WARNING:

It will not be possible to push or tow start a vehicle with automatic transmission. Only jump lead starting or the fitting of a fully charged battery is recommended.

Emergency starting using jump leads

Both the booster and discharged battery should be treated with great care when using jump leads. Always use high quality leads capable of carrying the starter current of the vehicle to be started.

Before commencing, the following precautions must be taken:

- When the battery of another vehicle is being used, ensure that the vehicles do not touch. Alternatively, remove the charged battery and place near to, not on, the vehicle with the discharged battery.
- Ensure that both vehicles have all electrical services OFF, the handbrake is ON and, with automatic transmission, 'P' is selected.
- Where the jump leads are of a different colour, e.g. red and black, use red for positive(+). This aids identification and helps to avoid crossing positive(+) to negative(-). Take extra care to avoid crossing the polarity when using cables of the same colour.

Caution:

1. **If using a jump start vehicle, under no circumstances should the vehicles come into contact with each other. This could establish an earth connection, which may cause sparks and damage.**
2. **Do not run the jump start vehicle's engine when boost starting a Jaguar Vehicle. If the jump start vehicle's engine is running and the jump leads are disconnected, damage to the Jaguar vehicle's electrical system will result.**
3. **The booster battery voltage must not exceed 12volts.**

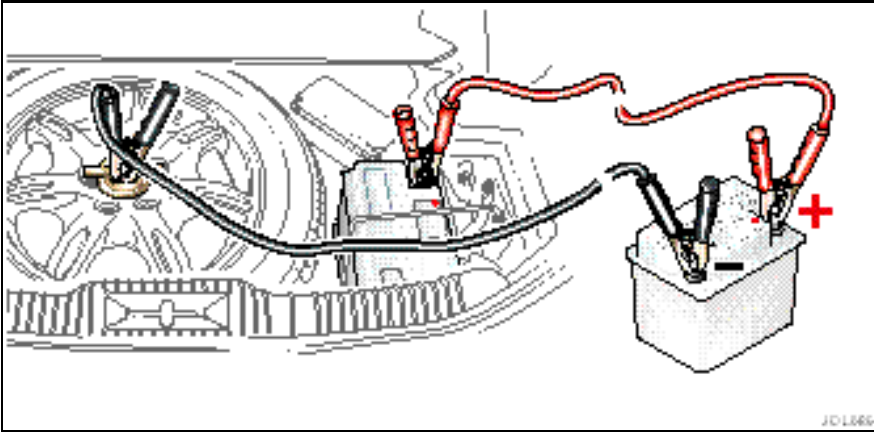

The following procedure must be followed exactly, being careful not to cause sparks:

1. Apply the handbrake, select 'P' (automatic transmission vehicles only), and turn off all the vehicles electrical services.
2. To gain access to the battery, fold the trunk floor panel forward.

3. Unclip the battery positive(+) terminal cover.
4. Attach one end of the red jump lead to the positive(+) terminal of the booster battery and the other end to the positive(+) terminal of the discharged battery. Make sure that a good connection is made.

Caution: Do not connect the negative jump lead directly to the negative (-) terminal of the discharged vehicle.

5. Attach one end of the black jump lead to the negative(-) terminal of the booster battery and the other end to an earth point on the vehicle being started. (If your Jaguar has the discharged battery use only the spare wheel locking stud, as shown). The earth point must be at least 12 inches (305mm) from the discharged battery. Make sure that a good connection is made.
6. When started, allow the engine to idle for five minutes before disconnecting the cables.
7. Disconnect the black jump lead from the earth point and the booster battery negative (-) terminal.
8. Disconnect the red jump lead from the positive(+) terminals of both batteries.
9. Refit the positive(+) terminal cover.
10. Refit the trunk floor panels.

5-4 Roadside emergency

Wheel changing and jacking

Be prepared for a flat tyre. Know where equipment is stowed and read the wheel changing and jacking instructions carefully.

Pull off the road completely, clear of all traffic and park on as level, solid ground as possible. Switch on hazard warning lights and, where legally required, display the warning triangle.



WARNING:

It can be dangerous to change a wheel when the vehicle is on a slope or soft, uneven ground.

The spare wheel and jacking equipment are stored in the trunk, under the floor panel.

To remove the spare wheel, fold the trunk floor panel towards the rear seats. Unscrew the retaining nut (A) and remove the spare wheel. Unscrew the retaining nut (B) and remove the jack and wheel nut wrench (and locking wheel nut kit, if fitted).

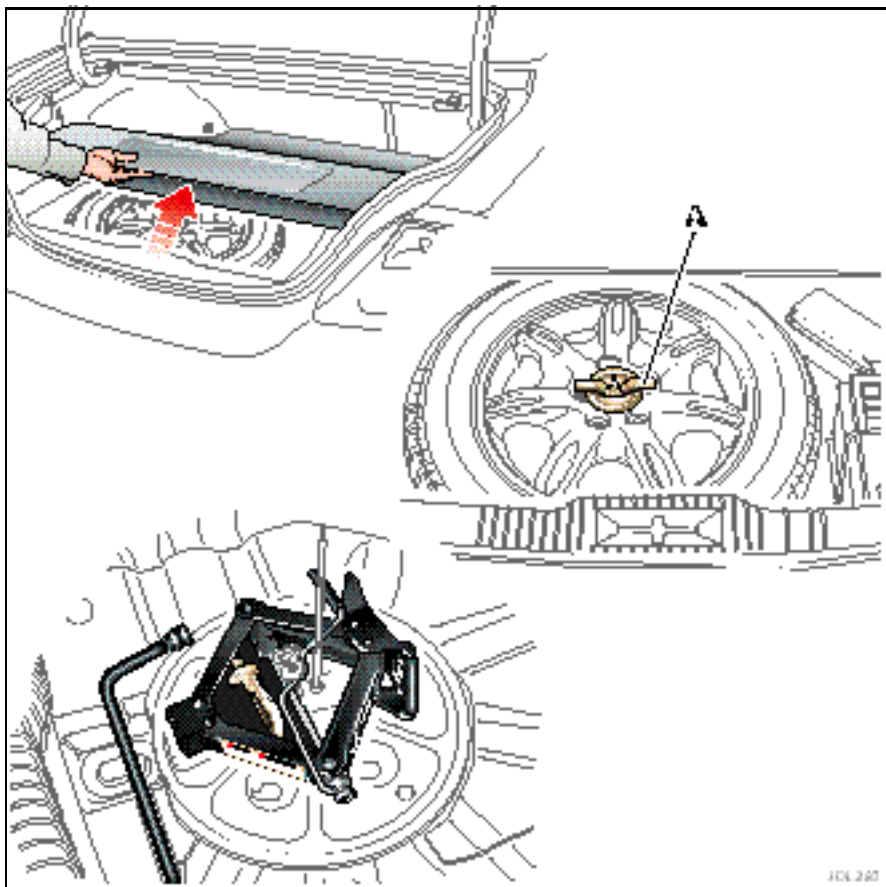

Wheel changing and jacking (continued)

Removing locking wheel nuts (where fitted)

Some vehicles are fitted with one locking wheel nut on each wheel. These can only be removed using the extractor tube and key socket provided.

The locking wheel nut has a cover which makes it visually similar to standard wheel nuts. The top of the cover has an indentation (A) to aid identification.

Push the extractor tube firmly over the locking wheel nut cover, as shown at (B), until it is fully located.

Withdraw the extractor tube to remove the cover.

Fit the key socket over the locking wheel nut as shown at (C).

Fit the wheel nut wrench over the key socket and loosen the locking wheel nut.

Locking wheel nut security coding

Locking wheel nuts have a letter stamped on their upper surface. The key socket is stamped with a corresponding number. Only key sockets with the correct matching number will fit the locking wheel nut.

Should a new key socket be required, note the letter on the locking wheel nut and contact your Jaguar Dealer. Proof of vehicle ownership will be required.

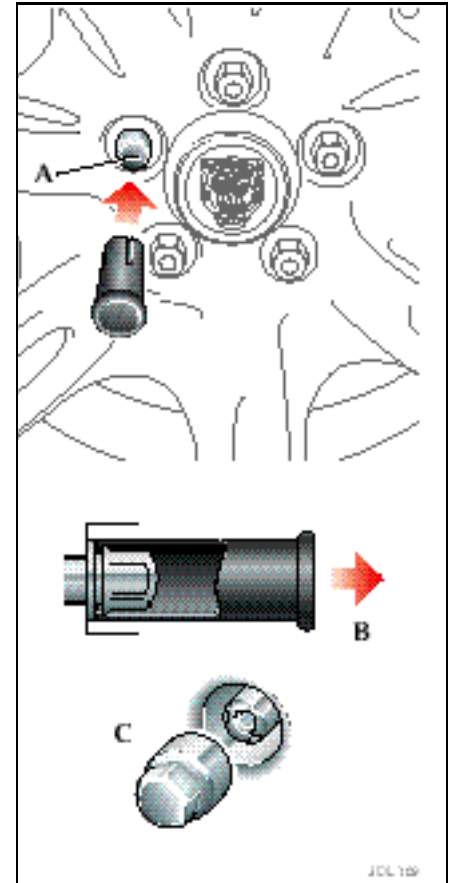

5-6 Roadside emergency

Wheel changing and jacking (continued)

Note:

1. Ensure that all passengers are in a safe place, clear of the vehicle.
2. Firmly apply the handbrake and for automatic vehicles, select gear position 'P' (Park).
3. Ensure that the jack is on firm and level ground.



WARNING:

Before attempting to lift the vehicle with the jack, block a wheel diagonally opposite to the wheel being replaced to prevent the vehicle from rolling when jacked up.

Before raising the vehicle, using the wheel nut wrench, slacken, but do not remove the wheel nuts.



WARNING:

Never work under the vehicle using only the jack as a support, always use axle stands or suitable supports under the jacking points.

Observe the instructions printed on the jack.

Use the jack only for lifting the vehicle during wheel changing, and only use the jack which is stored in the vehicle.

Do not start or run the engine while the vehicle is only supported by a jack.

Note: When one rear wheel is lifted off the ground the automatic transmission 'P' (Park) position will not prevent the vehicle from moving and possibly slipping off the jack.

Caution: Ensure that when anyone requires to raise the vehicle that the jacks are correctly positioned to avoid any damage to the vehicle sills, sill panels or aluminium components. Use only the correct jacking points.

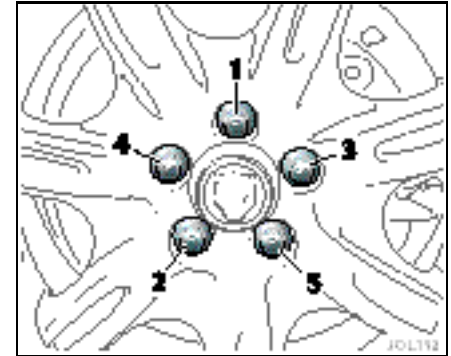
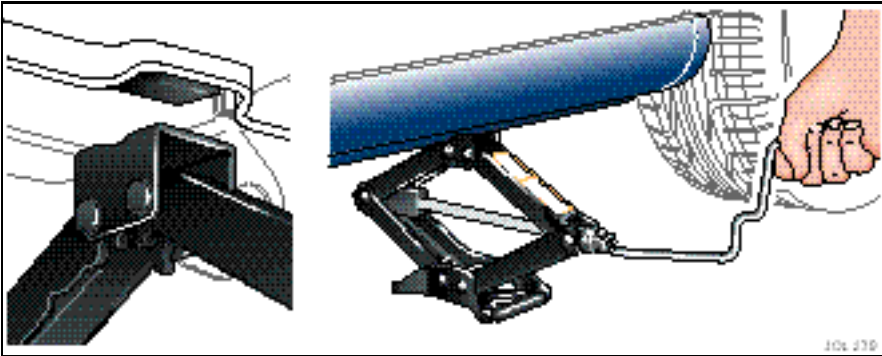

Wheel changing and jacking (continued)

There are four jacking points, two each side of the vehicle on the underside of the floor. These provide positive location for the jack. The front jacking point is approximately 7 inches (180 mm) from the front wheel and the rear is approximately 11 inches (280mm) forward of the rear wheel. The simplest way to correctly locate the jacking point is to feel along the sill panel to the cut-away portion and then fit the jack to the body, not to the sill.

Caution: Never use bumpers or any other part of the body to lift the vehicle.



WARNING:
Do not attempt to lift the vehicle unless the jack arm is fully engaged in the jacking point.

Place the jack squarely beneath the appropriate jacking point. Ensure that the jack arm is fully engaged. Carefully raise the vehicle by turning the handle. Stop jacking the vehicle when the tyre just clears the ground. Minimum tyre lift gives maximum vehicle stability.

Remove the wheel nuts and the wheel.

Fit the spare wheel and loosely secure with the wheel nuts.

Using the wheel nut wrench, lightly tighten the wheel nuts alternately using the sequence shown in the illustration.

Lower the jack and tighten the wheel nuts alternately,
DO NOT OVERTIGHTEN.

At the earliest opportunity have the wheel nuts tightened with a torque wrench to 94 lbf.ft (128Nm). This torque must not be exceeded.

5-8 Roadside emergency

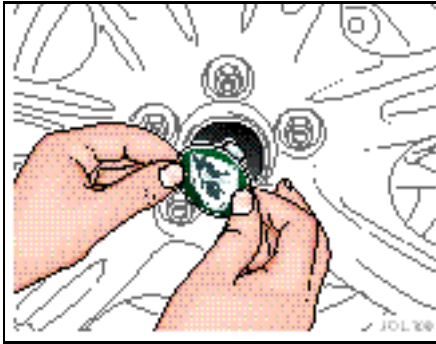

Stowing the equipment

Stow the jack and wrench.

Stow the replaced road wheel in the trunk, position the wheel and secure with the retaining nut. Reposition the trunk floor panel.

Note: Examine the jack occasionally, clean and grease the threads to ensure it is always ready for an emergency.

Wheel changing and jacking (continued)

Remove the jack from the vehicle.

When changing the road wheels, transfer the centre badge to the replacement wheel. Using the rounded end of the wheel nut wrench handle from the inside of the wheel, push the centre badge from its housing. Push the centre badge into the replacement wheel.

Vehicle recovery

The preferred vehicle recovery method is by using a flat bed transporter or rear suspended tow.

Caution:

- If the vehicle has defective transmission, to prevent further damage, it must be towed with the rear wheels clear of the ground.
- Ensure that the recovery team do not tow with sling-type equipment since damage to the bodywork may result.
- Do not tow vehicle by suspending the front end.

Transporting

If the vehicle is being transported on a trailer or vehicle flat bed transporter, the handbrake must be applied, the wheels chocked and the gear selector lever moved to position 'N' or 'D' but NEVER to 'P'.

The vehicle must be securely tied down to the transporter or trailer. There are four transporter tie-down brackets on the vehicle underbody. Do not attach tie-down hooks to the towing eye.

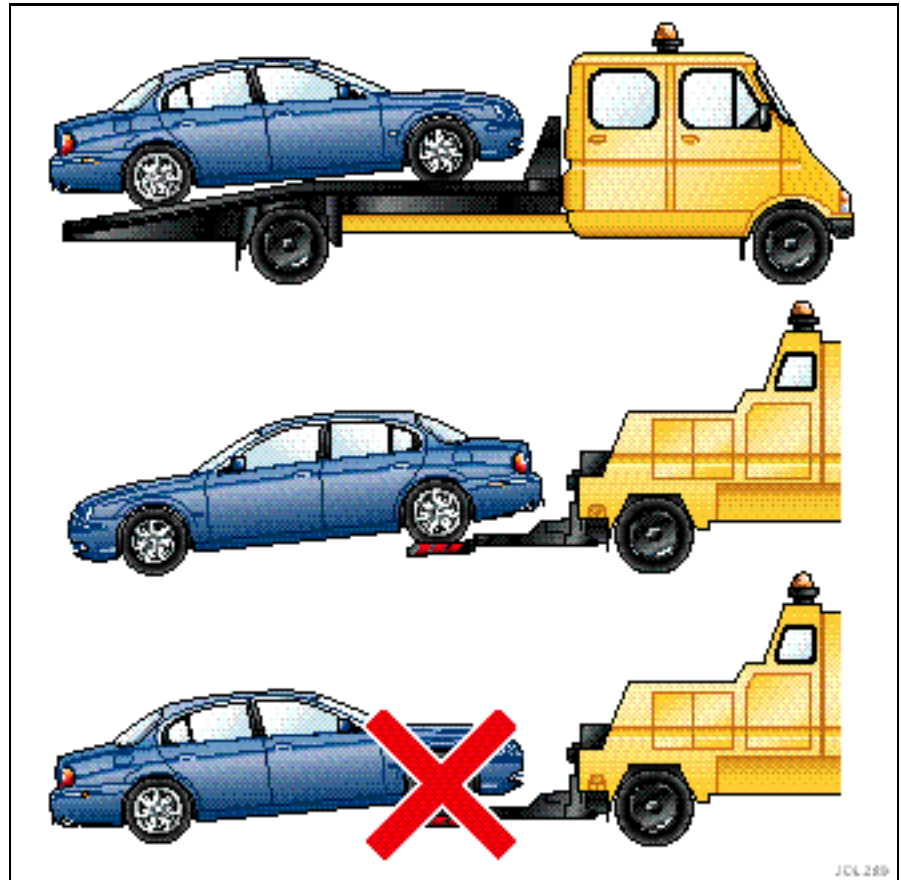

5-10 Roadside emergency

Vehicle failure

The removable towing eye is primarily for emergency use when towing for SHORT DISTANCES, e.g. removing the vehicle if it is causing an obstruction or for winching the vehicle onto a recovery transporter. To prevent damage to the automatic transmission, the towing distance must be restricted to 0.5 miles (0.8km) and towing speed must not exceed 48km/h.

Always obey towing regulations: In certain countries the registration number of the towing vehicle and an 'ON TOW' sign or warning triangle must be displayed in a prominent position at the rear of the vehicle being towed.

When being towed, the vehicle's gear selector lever must be in neutral (position 'N') with the ignition key turned to position 'II' to render the indicators, horn and brake lights operational.



WARNING:

When the engine is not running the steering and brakes will no longer be power-assisted. Therefore, be prepared for relatively heavy steering and the need for greatly increased brake pedal pressure.

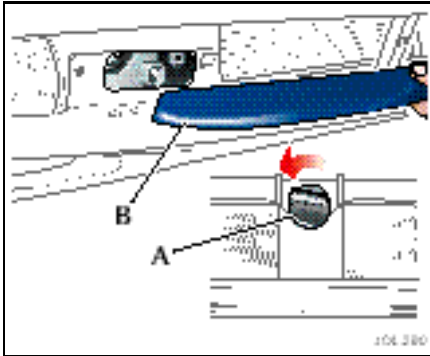

Towing eye

A towing eye is provided in the trunk, with the jack.

Caution:

- The towing eye is not suitable for 'solid bar towing'.
- Care must be taken to avoid damaging the bumpers and front apron.
- Do not tow vehicle by suspending the front end.

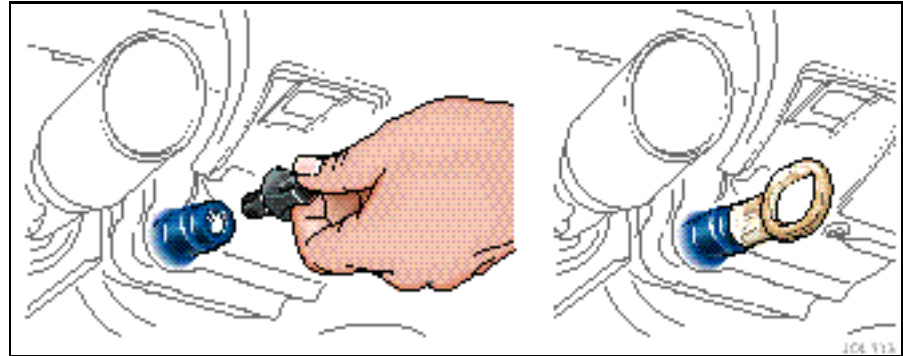

The front towing point is the right-hand bumper mounting bracket.

Turn the three fasteners(A) anti-clockwise and remove the grill vane(B).

Remove the protective bung and screw the eye into the vehicle, right up to the shoulder.



WARNING:

Avoid body contact with a hot exhaust pipe when fitting the eye to the rear towing point.

The rear towing point is alongside the left-hand exhaust pipe.

As with the front, remove the protective bung and screw the eye into the vehicle, right up to the shoulder.

New Jaguar S-TYPE 2003MY

Operation of Electric Park Brake –Vehicles in Transit

Operational Key Points

This vehicle is fitted with an Automatic Electric Park Brake Mechanism

This vehicle is also fitted with a transit device, which disconnects the vehicles electrical system from the vehicle battery when the ignition is switched off

As a result the following will occur

- Electric park brake will automatically be engaged each time the ignition is turned off
- A message will be displayed on the instrument panel message center which reads "**Apply Park Brake**" when the ignition is switched on
- **To move the vehicle**, the brake pedal must be depressed while lifting the Electric Park Brake Switch upwards (EPB switch is located behind the selector lever see fig. 1) . This will initialise the Electric Park Brake System
- Once Electric Park Brake System has been initialised the park brake will disengage automatically once the vehicle begins to move.

Failure to adhere to this procedure will result in the rear brake discs overheating which may cause the brake disc bags to catch fire. Additional vehicle components may also be damaged.

All expenses required to repair the vehicle will be charged to the appropriate party.

New Jaguar S-TYPE 2003MY

Please ensure that all relevant personnel responsible for unloading / loading vehicles are familiar with this procedure. This will need to be reviewed with each team



Figure 1



Figure 2



Figure 3